

The Network of Networks.

3M™ No Polish ST Connector SM and MM, Flat Splice, 250/900 μm

Instructions

Safety Precautions

Protective Eyewear

CAUTION

To reduce the risk associated with eye injury:
- Safety glasses should be worn when handling chemicals and cleaving the optical fiber.

Chemical Precautions

WARNING

To reduce the risk associated with fire:
- Storage, use and disposal of isopropyl alcohol should be per your company health, safety and environmental instructions. Refer to material safety data sheet for health hazards, safe handling, proper use and control measures.

CAUTION

To reduce the risk associated with eye or skin irritation from fiber gel in connector:
- Product contains phenylmethyl silicone (63148-58-3), hydrophobic silica (68611-44-9) and may cause minimal eye irritation. Avoid contact with eyes and wash hands before eating or smoking. Upon eye contact, immediately flush eyes with water while holding eyelids open and continue flushing for ten minutes. Contact a physician. Upon skin contact, wash with soap and water. Product Information: Material Safety Data Sheet or call 3M at 1-800-364-3577 or 651-737-6501 (24 hours).

Bare Fiber Handling

CAUTION

To reduce the risk associated with handling sharp glass fibers:
- Cleaved glass fibers are sharp and can pierce the skin. Use tweezers when handling shards and dispose of them properly per your company health and safety instructions.

Fiber/Cable Handling

NOTICE

To reduce the risk associated with fiber damage:
- Optical fiber can be damaged by excessive tensile, compressive and bending forces. Consult the manufactures' specifications for proper handling instructions. Laser Safety

Laser Safety

CAUTION

To reduce the risk associated with eye damage from exposure to laser light:
- Take the proper precautions when working with optical fiber because invisible laser light may be present. The principal laser hazard when working with fiber optics is injury to the eye. Never look directly into the fiber or connector using the naked eye or a microscope.

2.3 Move the guide funnel forward on the fiber holder until it stops; open doors and fiber clamp.

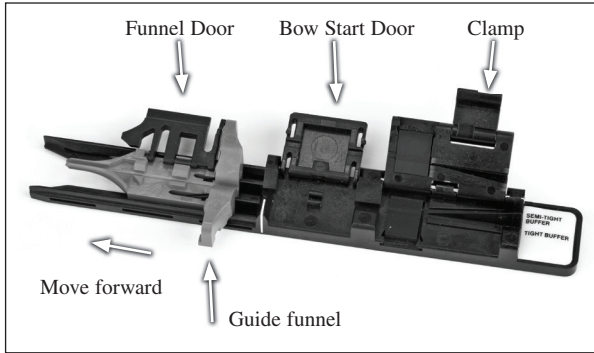

2.4 Strip, clean and cleave the fiber to 8 ± 0.5 mm ($.32 \pm .02$ inches) measured from the end of the $900 \mu\text{m}$ buffer. Use the cleave length marker on the assembly base to verify the length. Refer to the notes at the beginning of this section when using loose tube or semi-tight buffered fiber.

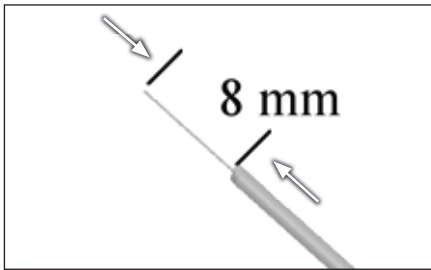

2.5 With the guide funnel fully forward, lay the fiber in the central groove along the length of the fiber holder as shown. Position it such that the stripped and cleaved portion extends slightly beyond the tip of the guide funnel.

If the fiber has a noticeable amount of curvature, orient it so the curvature is directed downward toward the fiber holder. In the clamp area of the fiber holder, place the fiber in the appropriate groove depending on whether it is TIGHT BUFFER, or SEMI-TIGHT BUFFER (loose tube).

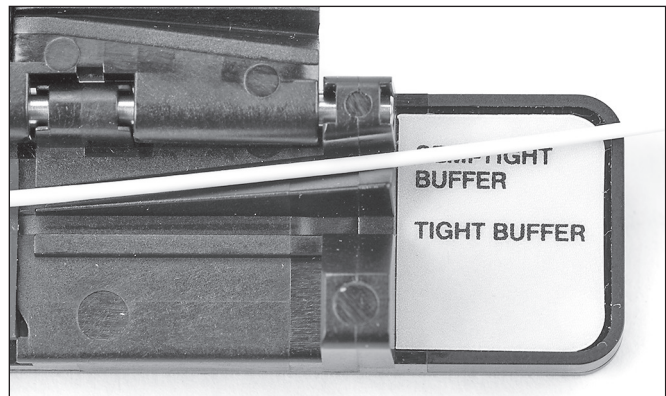
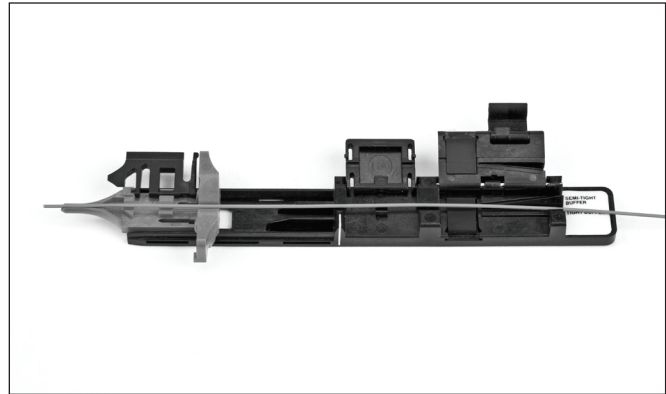

900 μm semi-tight buffer fiber

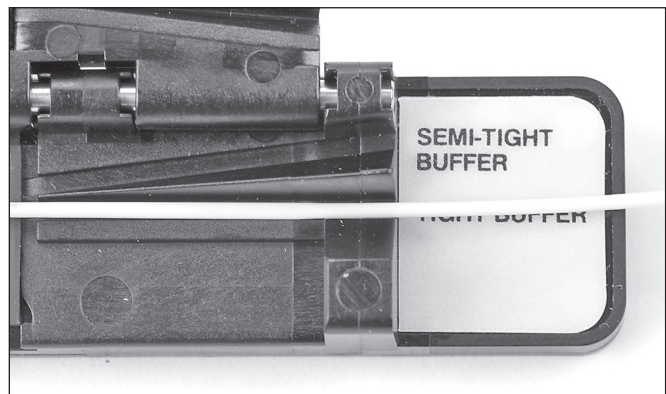

900 μm tight buffer fiber

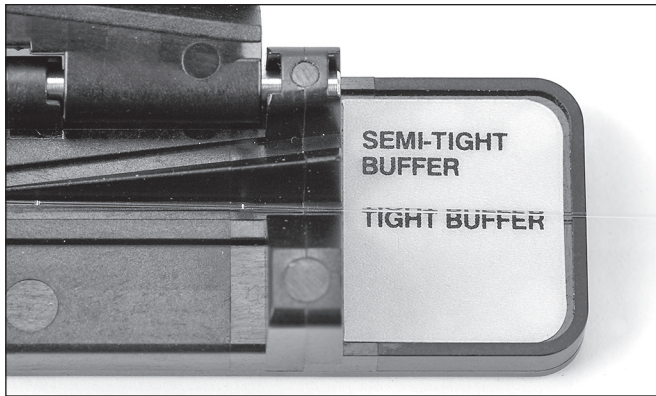

250 μ m fiber

- 2.6 Close the funnel door and bow start door on the fiber holder. Again ensure that the guide funnel is pushed completely forward to the end of the fiber holder. Pull the fiber back until the fiber tip is flush with the end of the funnel. To verify the cleave length is still correct, all coatings should align with the hole located in the funnel. Close the back clamp.

Note: for semi-tight buffer fiber, the 250 μ m coating may protrude up to 1 mm past the 900 μ m buffer. If necessary, re-strip, clean and cleave the fiber to meet length requirements.

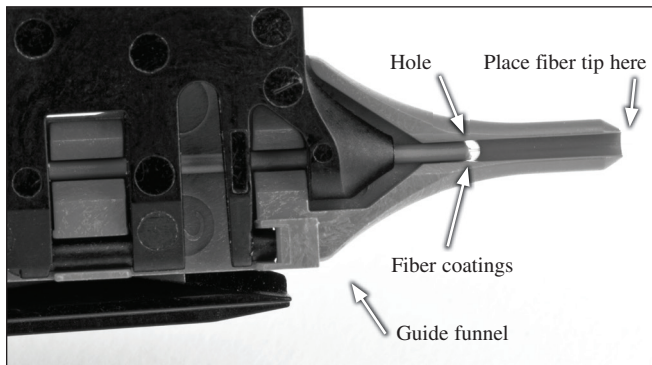

- 2.7 Place fiber holder in assembly base and slowly slide fiber holder forward, toward the connector.

Note: Allow 10 seconds for this movement from the time the fiber begins to enter the boot on the connector until the fiber holder bottoms out in the assembly base.

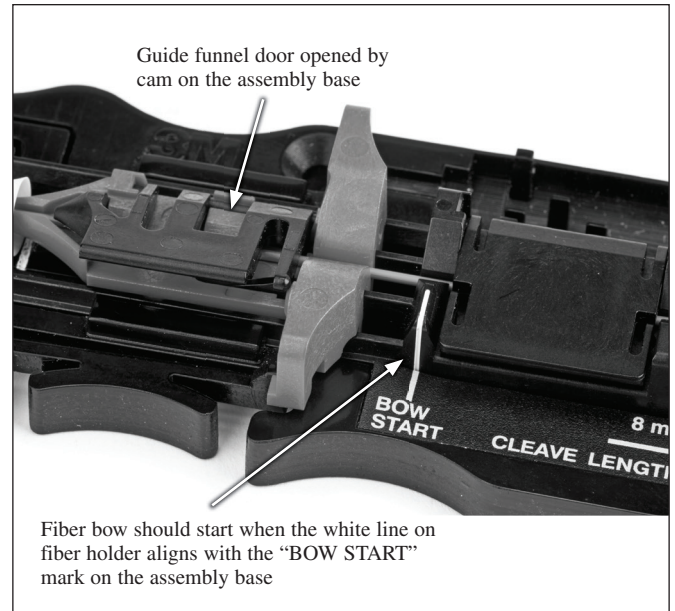
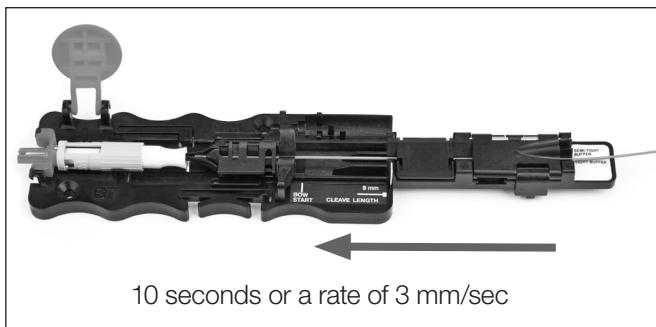

- 2.8 While slowly sliding the fiber holder toward the connector, a bow should start to form in the fiber when the white line on the fiber holder aligns with the white BOW START line on the assembly base. If a bow is not seen, slide the fiber holder back. If a bow is not seen, or if a bow is seen before the two white lines meet, slide the fiber holder back. Re-strip, clean and cleave the fiber, and begin the termination process again.

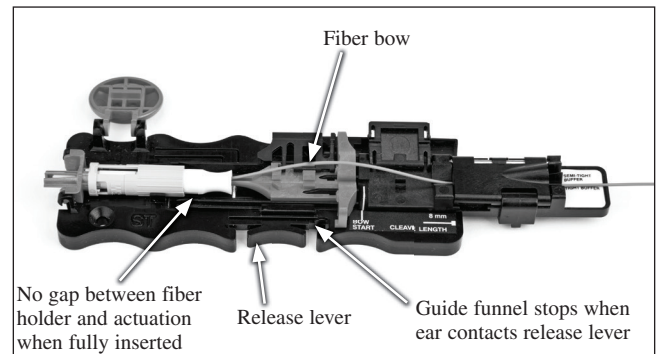

- 2.9 Continue to slowly slide fiber holder towards connector until it stops. Verify fiber bow again.

Note: The fiber will bow and lift the middle cover for rigid fibers and remain closed for 250 μ m and especially flexible 900 μ m fibers. This ensures proper fiber insertion force.

2.10 While maintaining the fiber bow, firmly press the element actuator button to actuate the splice element within the connector.

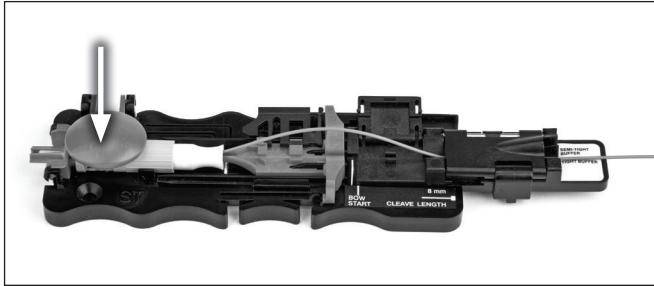

Note: Never activate a connector without a fiber in it or with a fiber only partially inserted. Doing so will ruin the connector by blocking fiber from being fully inserted.

2.11 OPTIONAL TESTING STEP: If the connector is to be tested and potentially reused, this needs to be done at this point in the termination process. To do so, carefully remove the fiber holder and connector from the assembly base by following steps 2.13 through 2.16. Use extra care when handling the connector and fiber as the 900 μ m buffer has not yet been secured. The connector may now be tested. If the connector passes the test, reinstall it into the receptacle (2.2), reinsert the fiber holder into the assembly base being careful to avoid damaging the fiber, and proceed with step 2.12.

To remove the connector from the fiber, place it into the cap popper cavity on the assembly base oriented as shown. Then press down firmly using equal pressure at each end of the connector. This action will pop the element activation cap upward thereby opening the splice element. Separate the fiber and connector, and restart the termination process from the beginning.

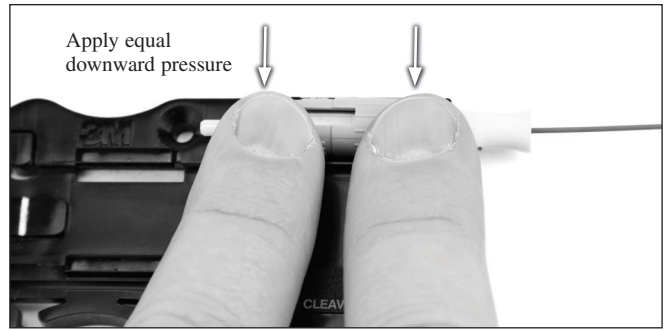

2.12 To activate the 900 μ m buffer crimp at the rear of the connector, press and hold inward on the release lever located on the side of the assembly base, and push the guide funnel by the ears toward the connector until it stops.

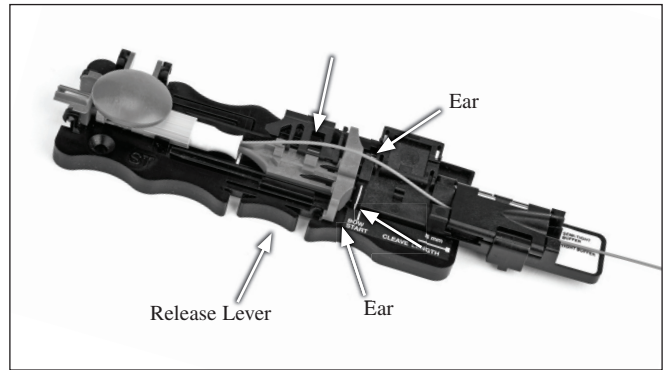

2.13 Release and lift the fiber clamp and raise the doors to release fiber.

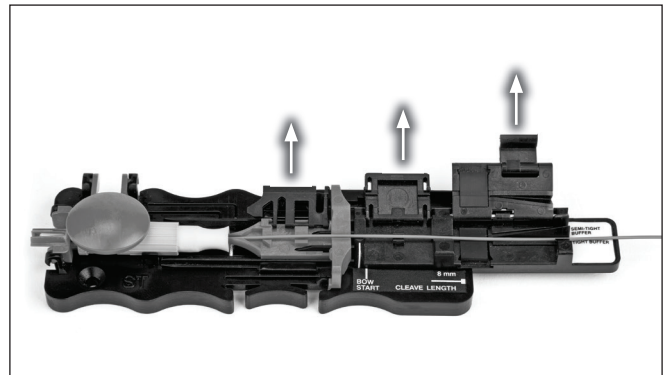

2.14 Slide fiber holder from actuation tool.

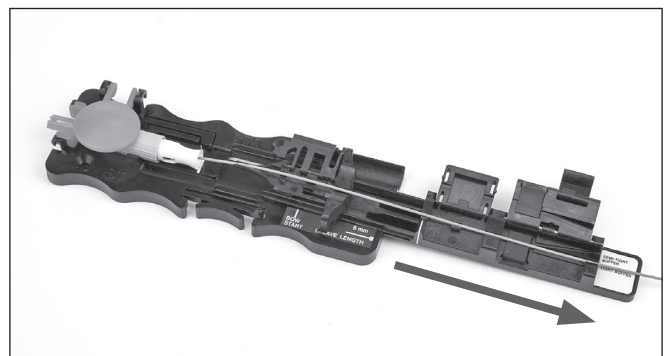

2.15 Raise the element actuation button.



2.16 Pull connector from the receptacle.



3M™ No Polish ST Connectors, Kit and Tool Descriptions	Packaging
8840 No Polish Connector ST SM Plug 250/900 μm with tool (blue housing)	12 or 60/package*
6840-50 No Polish Connector ST MM 50 μm 250/900 μm with tool (black housing)	12 or 60/package*
6840-50/LOMMF No Polish Connector ST MM 50 μm 250/900 μm LOMMF with tool (aqua housing)	12 or 60/package*
6840-62.5 No Polish Connector ST MM 62.5 μm 250/900 μm with tool (beige housing)	12 or 60/package*
8865 No Polish Connector Kit	1/package
8865-C No Polish Connector Kit with Cleaver	1/package
8845-AT No Polish Connector ST Assembly Tool	1/package

*"RoHS Compliant 2002/95/EC" means that the product or part ("Product") does not contain any of the substances in excess of the maximum concentration values in EU Directive 2002/95/EC, as amended by Commission Decision 2005/618/EC, unless the substance is in an application that is exempt under EU RoHS. This information represents 3M's knowledge and belief, which may be based in whole or in part on information provided by third party suppliers to 3M.

3M™ No Polish Connector Kit 8865-C with Cleaver

- Kit Contents:
- 8865-AT No Polish SC Connector Assembly Tool 250/900 μm
 - 8835-AT No Polish LC Connector Assembly Tool 250/900 μm
 - 8845-AT No Polish ST Connector Assembly Tool 250/900 μm
 - 2534 Fiber Cleaver (not included in 8865 kit)
 - 6365-ST Stripping Tool
 - 6365-KS Aramid Yarn Snips
 - Lint-Free Cloths (100/pkg)
 - Cleaning Alcohol Bottle



3M is a trademark of 3M Company.

Important Notice

All statements, technical information, and recommendations related to 3M's products are based on information believed to be reliable, but the accuracy or completeness is not guaranteed. Before using this product, you must evaluate it and determine if it is suitable for your intended application. You assume all risks and liability associated with such use. Any statements related to the product which are not contained in 3M's current publications, or any contrary statements contained on your purchase order shall have no force or effect unless expressly agreed upon, in writing, by an authorized officer of 3M.

Warranty; Limited Remedy; Limited Liability.

This product will be free from defects in material and manufacture for a period of one (1) year from the time of purchase. **3M MAKES NO OTHER WARRANTIES INCLUDING, BUT NOT LIMITED TO, ANY IMPLIED WARRANTY OF MERCHANTABILITY OR FITNESS FOR A PARTICULAR PURPOSE.** If this product is defective within the warranty period stated above, your exclusive remedy shall be, at 3M's option, to replace or repair the 3M product or refund the purchase price of the 3M product. **Except where prohibited by law, 3M will not be liable for any indirect, special, incidental or consequential loss or damage arising from this 3M product, regardless of the legal theory asserted.**



Communication Markets Division

6801 River Place Blvd.
Austin, TX 78726-9000
1-800-426-8688
www.3m.com/Telecom

Please Recycle. Printed in USA.
© 3M 2012. All Rights Reserved.
78-0013-6978-0-B